

DETAIL 1  
SCALE: 1/2" = 1'-0"  
S7

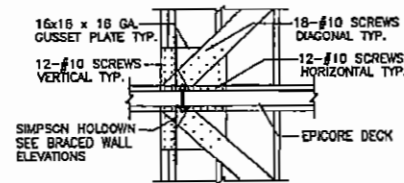

DETAIL 2  
SCALE: 1/2" = 1'-0"  
S7

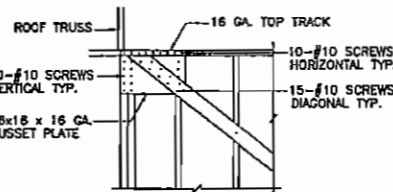

DETAIL 5  
SCALE: 1/2" = 1'-0"  
S7

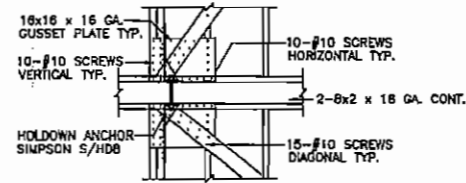

DETAIL 6  
SCALE: 1/2" = 1'-0"  
S7

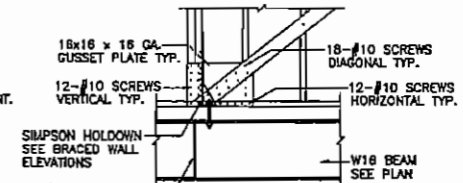

DETAIL 7  
SCALE: 1/2" = 1'-0"  
S7

**BRACED WALL FRAMING NOTES**

1. SEE DWG. S2, S3, S4, S5 & S8 FOR SHEAR WALL LOCATIONS.
2. INSTALL STRAP X-BRACING (4 IN. AND 6 IN.) ON ONE SIDE OF SHEAR WALL TYP.
3. INSTALL 16 GAGE TOP & BOTTOM STUD TRACK (CONTINUOUS) AT FLOOR AND ROOF LEVELS TYP.
4. ATTACH STUD TOP AND BOTTOM TRACK TO FLOOR WITH HILTI DS-37-P10 PINS, 2 EA. @ 16" O.C. TYP. ATTACH STRAP X-BRACING ENDS TO GUSSET PLATES AND GUSSET PLATES TO STUDS WITH HILTI 10-16x3/4 HWH#3 SCREWS TYPICAL.
5. INSTALL X-STRAPS TIGHT AGAINST STUDS IN SHEAR WALL. SLACK OR LOOSE STRAPS ARE NOT ACCEPTABLE.
6. ATTACH X-STRAPS TO INTERMEDIATE STUDS WITH ONE 10-16x3/4 HWH#3 HILTI SCREWS TYP.
7. DO NOT SPLICE MEMBERS (INCLUDING STRAP X-BRACING) WITHIN SHEAR WALLS TYP.

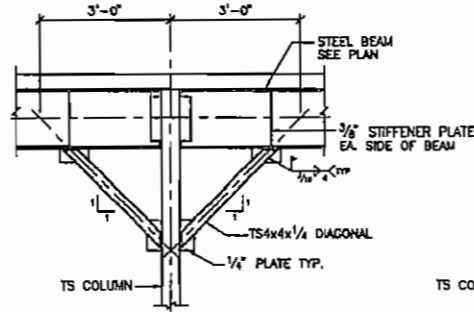

DETAIL 8  
SCALE: 1/2" = 1'-0"  
S7

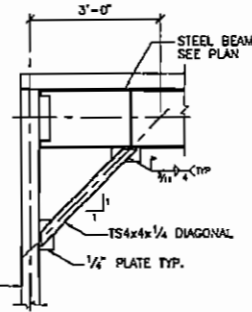

DETAIL 9  
SCALE: 1/2" = 1'-0"  
S7

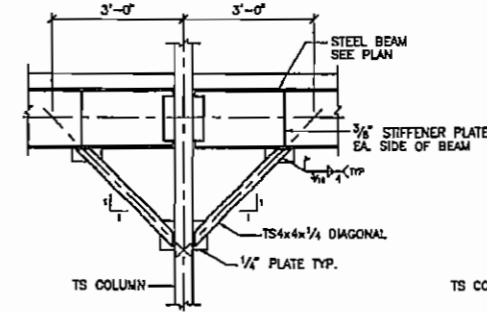

DETAIL 10  
SCALE: 1/2" = 1'-0"  
S7

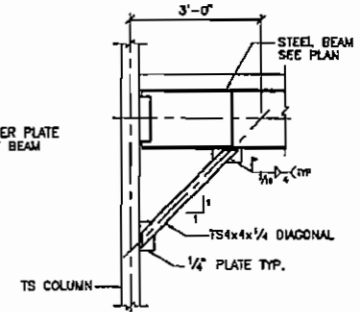

DETAIL 11  
SCALE: 1/2" = 1'-0"  
S7

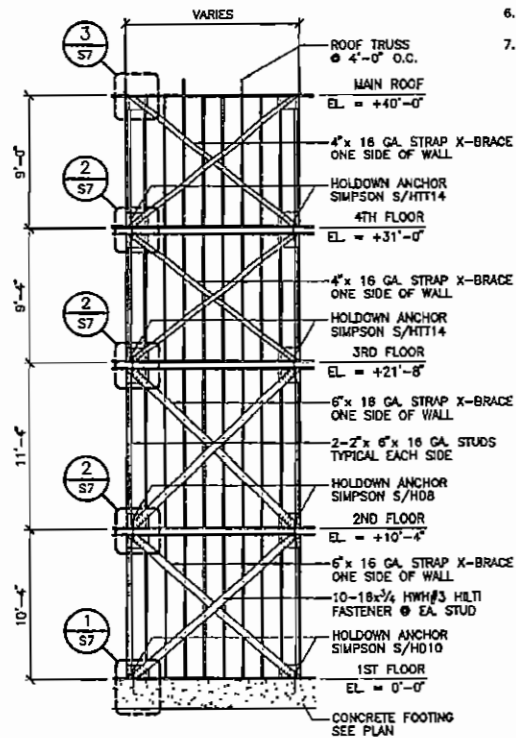

BRACED WALL 'BW1'

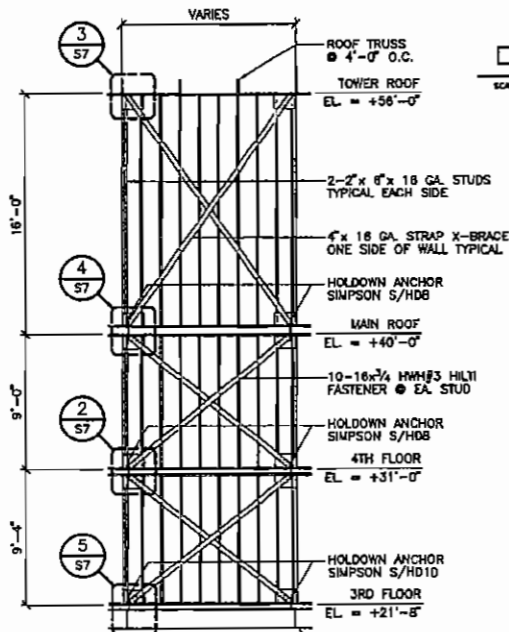

BRACED WALL 'BW3'

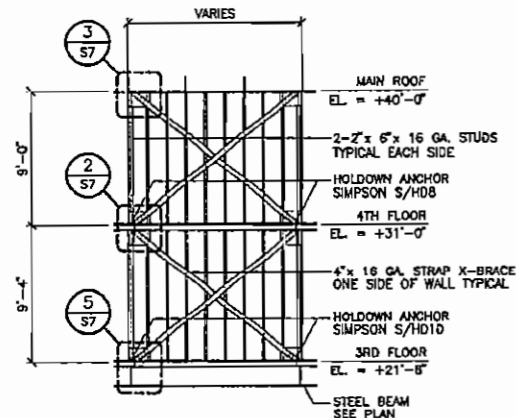

BRACED WALL 'BW2'

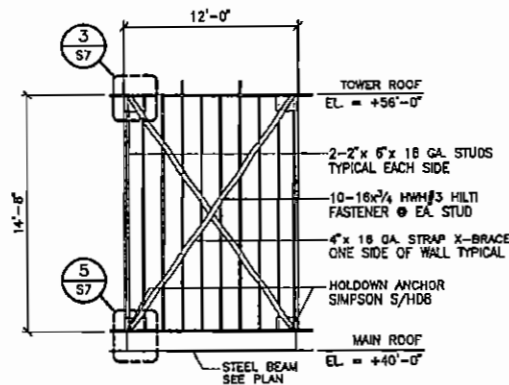

BRACED WALL 'BW4'

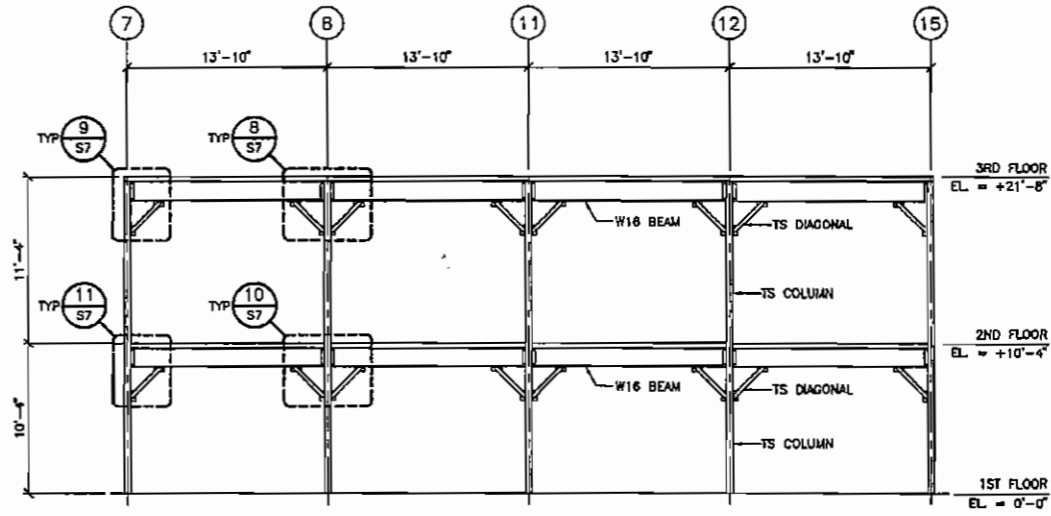

FRAME @ GRID 'D'

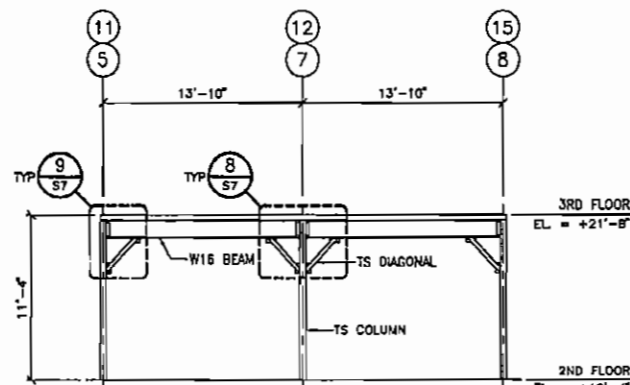

FRAME @ GRIDS 'A' & 'B'

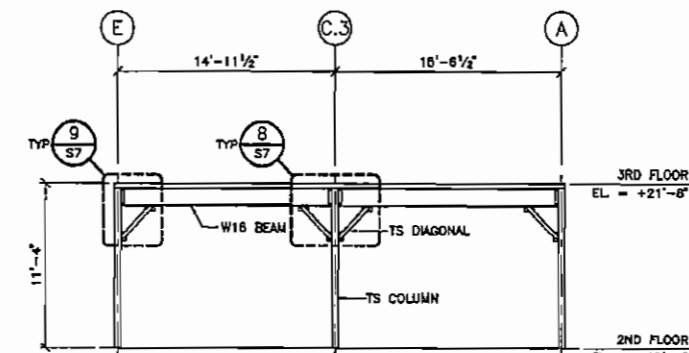

FRAME @ GRID '4'

ARCHITECTURAL DESIGN WORKSHOP P.C.  
814 COVERED BRIDGE WAY, FAIRBURN, GA. 30213  
TEL. 770.305.7464

CLIENT: Kasandas Properties  
PROJECT: New Comfort Suites Hotel  
Busbee Road, at Chastain Road, Kennesaw, Ga. 30144

No.	Description	Date

Project Number	6002
Date	3/06/07
Drawn By	RPK
Checked by	WHL
Scale	AS NOTED

Elevations & Details

S7

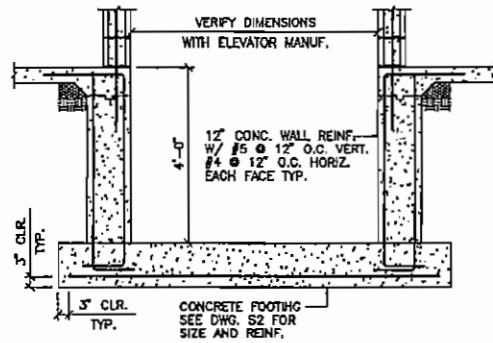

SECTION 1  
SCALE: 1/2" = 1'-0"  
SB

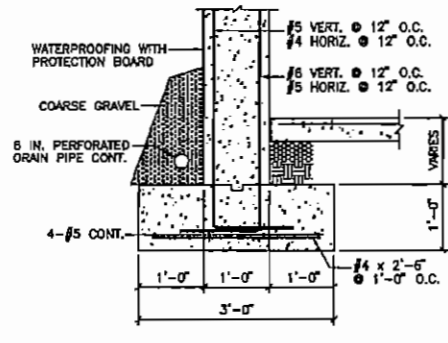

SECTION 2  
SCALE: 3/4" = 1'-0"  
SB

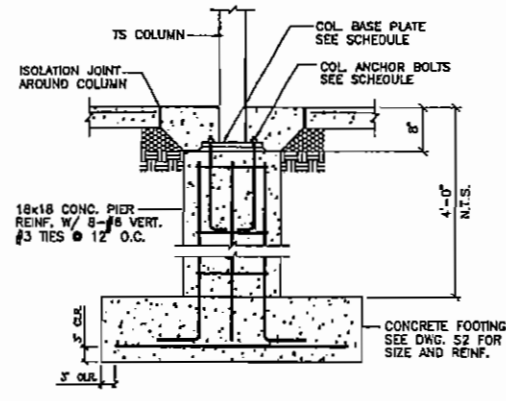

SECTION 3  
SCALE: 3/4" = 1'-0"  
SB

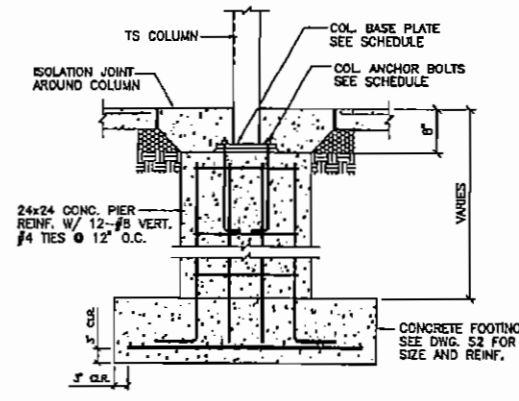

SECTION 4  
SCALE: 3/4" = 1'-0"  
SB

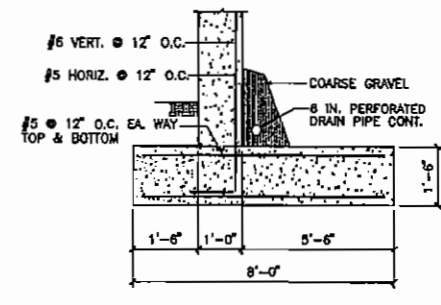

SECTION 5  
SCALE: 1/2" = 1'-0"  
SB

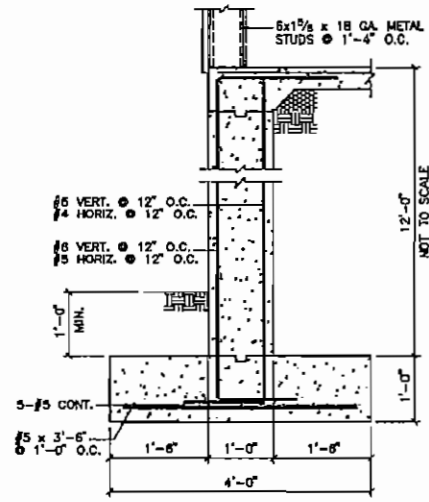

SECTION 6  
SCALE: 3/4" = 1'-0"  
SB

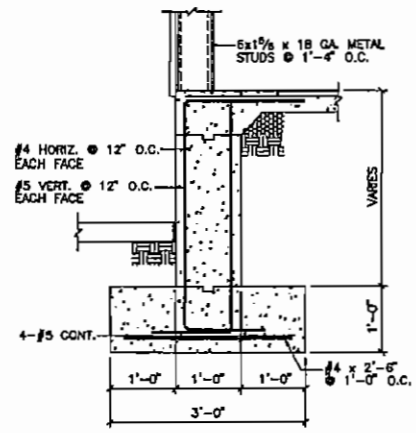

SECTION 7  
SCALE: 3/4" = 1'-0"  
SB

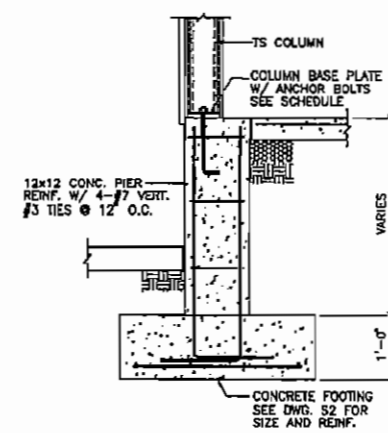

SECTION 8  
SCALE: 3/4" = 1'-0"  
SB

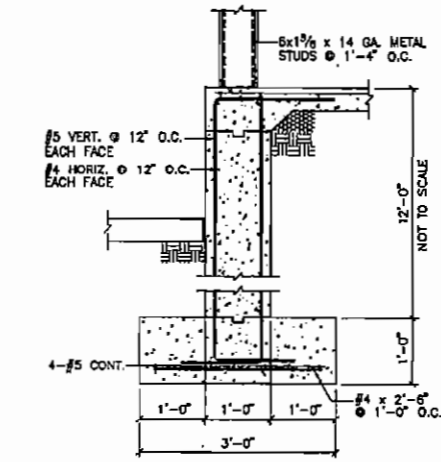

SECTION 9  
SCALE: 3/4" = 1'-0"  
SB

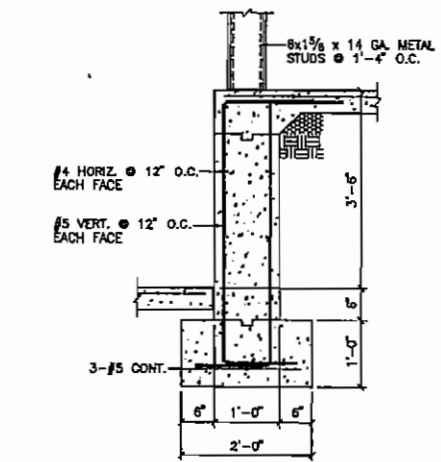

SECTION 10  
SCALE: 3/4" = 1'-0"  
SB

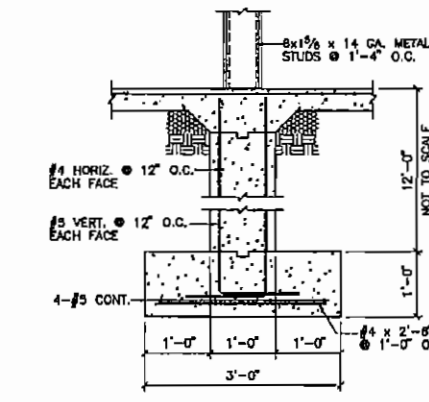

SECTION 11  
SCALE: 3/4" = 1'-0"  
SB

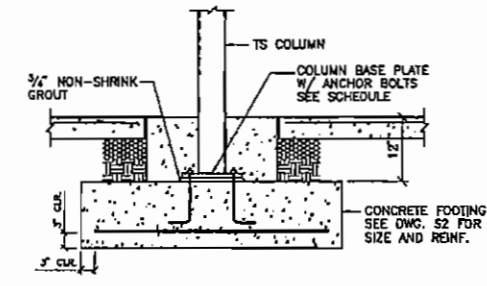

SECTION 12  
SCALE: 3/4" = 1'-0"  
SB

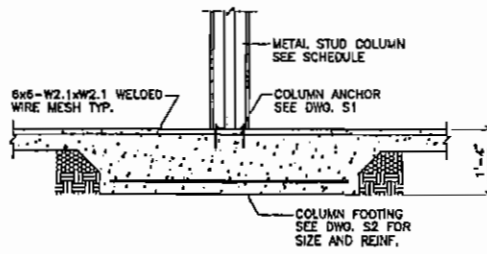

SECTION 13  
SCALE: 3/4" = 1'-0"  
SB

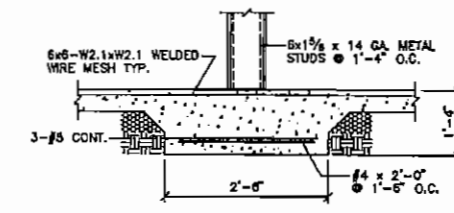

SECTION 14  
SCALE: 3/4" = 1'-0"  
SB

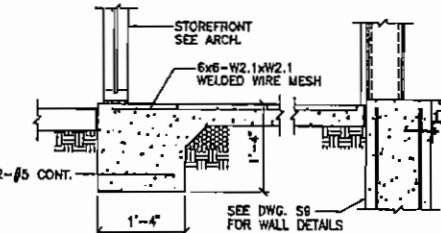

SECTION 15  
SCALE: 3/4" = 1'-0"  
SB

ARCHITECTURAL DESIGN WORKSHOP P.C.  
814 COVERED BRIDGE WAY, FAIRBURN, GA. 30213  
TEL. 770.308.7464

CLIENT: Kasandas Properties  
PROJECT: New Comfort Suites Hotel  
Busbee Road, at Chastain Road, Kennesaw, Ga. 30144

No.	Description	Date

Sections & Details

Project Number	0002
Date	3/05/07
Drawn By	TRK
Checked By	WHL
Scale	AS NOTED

S8

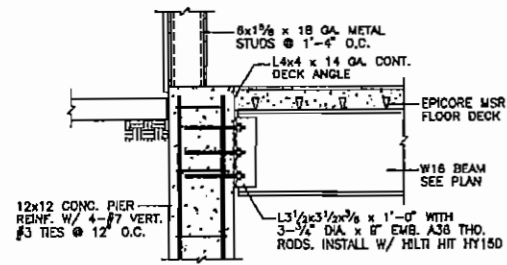

SECTION 1  
SCALE: 3/4" = 1'-0"  
S9

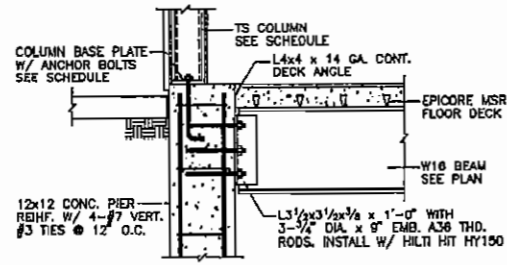

SECTION 2  
SCALE: 3/4" = 1'-0"  
S9

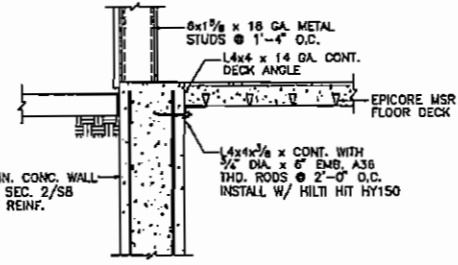

SECTION 3  
SCALE: 3/4" = 1'-0"  
S9

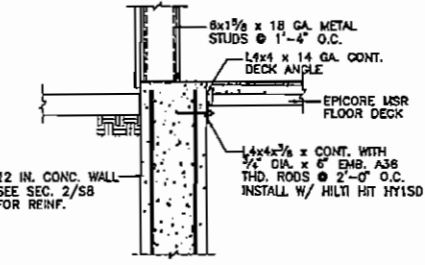

SECTION 4  
SCALE: 3/4" = 1'-0"  
S9

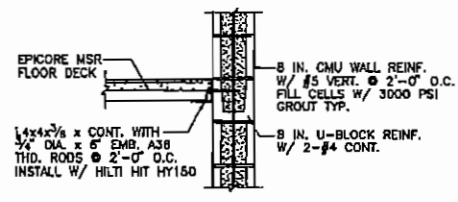

SECTION 5  
SCALE: 1/2" = 1'-0"  
S9

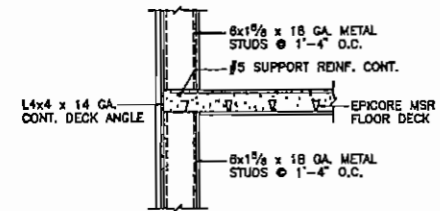

SECTION 6  
SCALE: 3/4" = 1'-0"  
S9

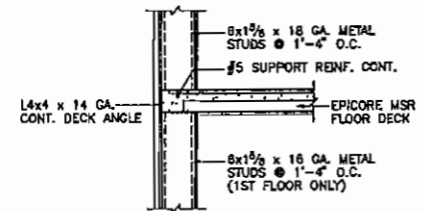

SECTION 7  
SCALE: 3/4" = 1'-0"  
S9

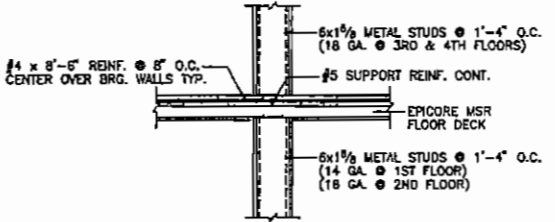

SECTION 8  
SCALE: 3/4" = 1'-0"  
S9

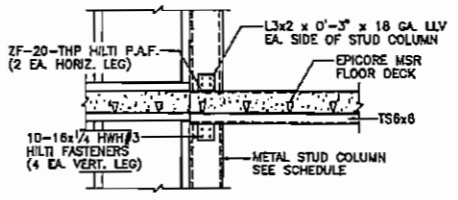

SECTION 9  
SCALE: 3/4" = 1'-0"  
S9

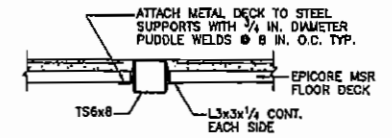

SECTION 10  
SCALE: 1/2" = 1'-0"  
S9

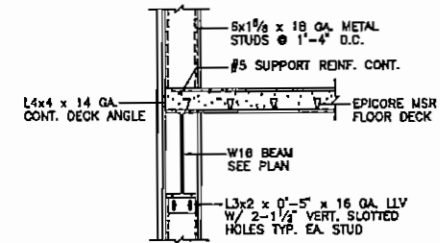

SECTION 11  
SCALE: 3/4" = 1'-0"  
S9

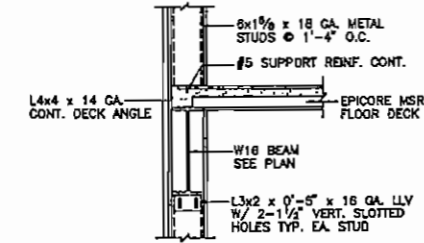

SECTION 12  
SCALE: 3/4" = 1'-0"  
S9

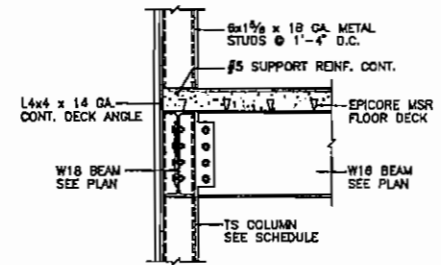

SECTION 13  
SCALE: 3/4" = 1'-0"  
S9

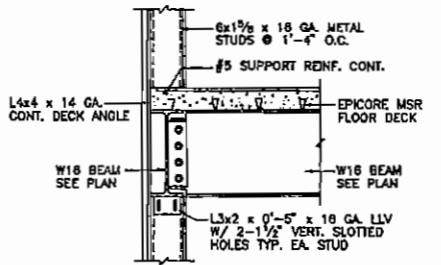

SECTION 14  
SCALE: 3/4" = 1'-0"  
S9

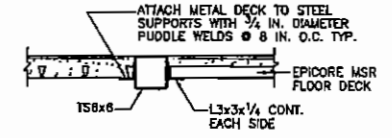

SECTION 15  
SCALE: 1/2" = 1'-0"  
S9

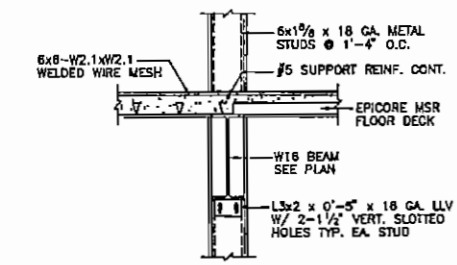

SECTION 16  
SCALE: 3/4" = 1'-0"  
S9

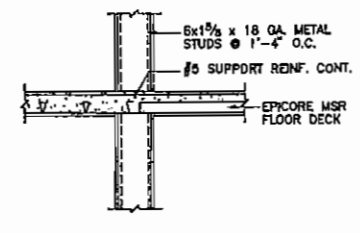

SECTION 17  
SCALE: 3/4" = 1'-0"  
S9

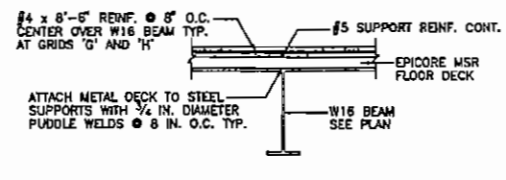

SECTION 18  
SCALE: 3/4" = 1'-0"  
S9

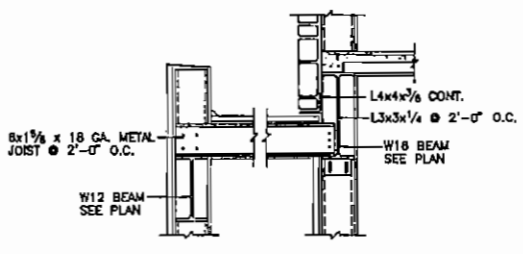

SECTION 19  
SCALE: 3/4" = 1'-0"  
S9

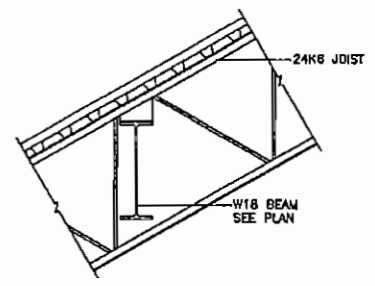

SECTION 20  
SCALE: 1/2" = 1'-0"  
S9

ARCHITECTURAL DESIGN WORKSHOP P.C.  
814 COVERED BRIDGE WAY, FAIRBURN, GA. 30213  
TEL 770 306 7484

CLIENT: Kasandas Properties  
PROJECT: New Comfort Suites Hotel  
Busbee Road, at Chastain Road, Kennesaw, Ga. 30144

No.	Description	Date

Sections & Details		AS NOTED
Project Number	6000	S9
Date	3/20/07	
Drawn By	HPK	
Checked By	WHL	
Scale		