

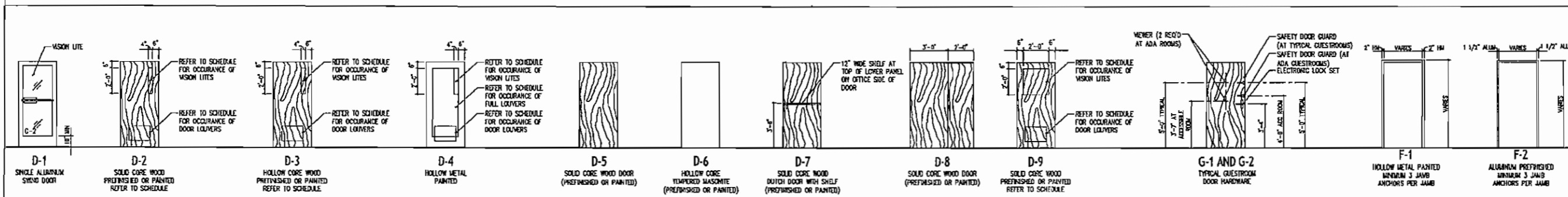

- DOOR NOTES:**
- 1) PAINT ALL TOPS AND BOTTOM OF HOLLOW METAL DOORS THAT ARE EXPOSED TO WEATHER
 - 2) ALLOW FOR PLASTIC LAMINATE FACES AT DOOR FRAMES. ADJUST HINGES AS REQ'D.
 - 3) PROVIDE HAZARD WARNINGS FOR VISUALLY IMPAIRED ON MECHANICAL ROOM DOOR HANDLES.
 - 4) REFER TO SPECIFICATIONS FOR DOOR HARDWARE
 - 5) SPRING HINGES ARE NOT ACCEPTABLE SUBSTITUTES FOR SPECIFIED DOOR CLOSURES
 - 6) PROVIDE FULL WIDTH MARBLE THRESHOLD AT BATHROOM DOORS
 - 7) ALL ALUMINUM SHALL BE A DARK BRONZE ANODIZED KYNAR 500 FINISH
 - 8) CARPET BASE SHALL BE PROVIDED AT ALL CARPET LOCATIONS AND CERAMIC TILE BASE SHALL BE PROVIDED AT ALL CERAMIC TILE LOCATIONS

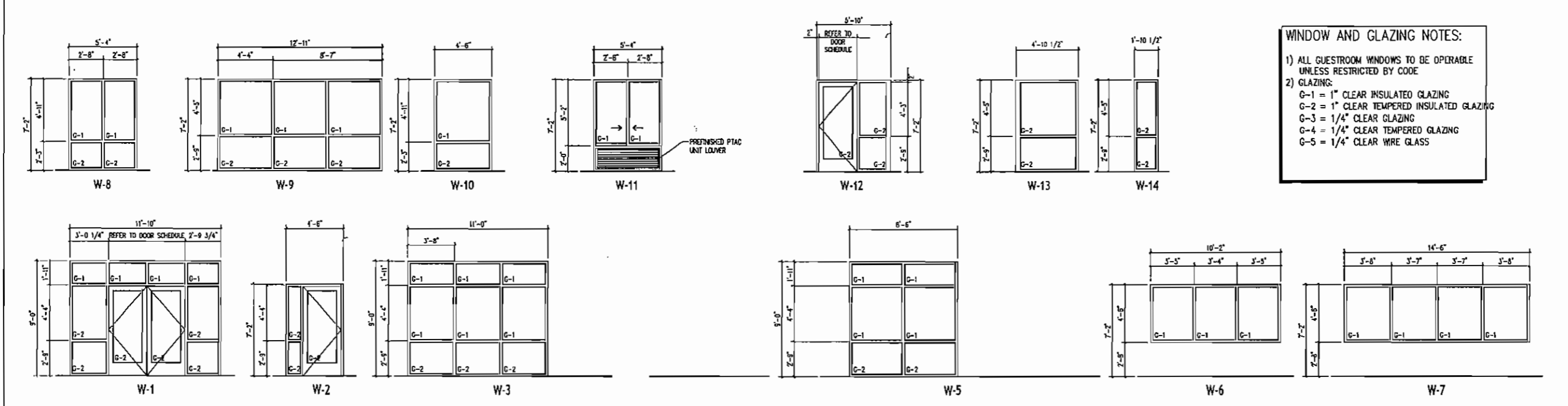

03 DOOR ELEVATIONS SCALE: 1/4"=1'-0" **02 FRAME ELEVATIONS**



- WINDOW AND GLAZING NOTES:**
- 1) ALL GUESTROOM WINDOWS TO BE OPERABLE UNLESS RESTRICTED BY CODE
 - 2) GLAZING:
 G-1 = 1" CLEAR INSULATED GLAZING
 G-2 = 1" CLEAR TEMPERED INSULATED GLAZING
 G-3 = 1/4" CLEAR GLAZING
 G-4 = 1/4" CLEAR TEMPERED GLAZING
 G-5 = 1/4" CLEAR WIRE GLASS

01 DOOR ELEVATIONS SCALE: 1/4"=1'-0"

ARCHITECTURAL DESIGN WORKSHOP P.C.
 814 COVERED BRIDGE WAY, FARGUSON, GA. 30213. TEL. 770.306.7464.
 PROJECT: New Comfort Suites Hotel
 Kasandas Properties
 Busbee Road, at Chestnut Road, Marietta, Ga. 30144

No.	Description	Date

COMFORT SUITES
 BY CHOICE HOTELS

Elevations : Doors & Windows

Project Number: 7003
 Date: 2/20/07
 Drawn by: VP
 Checked by: ID
 Scale: A601

MILLWORK GENERAL NOTES:

1. MILLWORK ELEVATIONS AND SECTIONS ARE PROVIDED FOR INFORMATION ONLY, AND ARE NOT INTENDED FOR CONSTRUCTION.
2. SUBMIT FINAL MILLWORK CONSTRUCTION DOCUMENTS FOR APPROVAL PRIOR TO FABRICATION.
3. FINISHED MILLWORK AND INSTALLATION BY GENERAL CONTRACTOR, OWNER SHALL PROVIDE ALL EQUIPMENT.
4. ALL SURFACES SHALL BE 3/4" PLYWOOD OR AS ALLOWED BY AW QUALITY STANDARDS #400 FOR "CUSTOM QUALITY MILLWORK".
5. PLASTIC LAMINATE AS SCHEDULED ON ALL EXPOSED SURFACES. WHITE MELAMINE IS ACCEPTABLE ON ALL NON EXPOSED INTERIOR SURFACES.



ARCHITECTURAL DESIGN WORKSHOP P.C.
 814 COVERED BRIDGE WAY, FARMINGDALE, GA. 30213. TEL. 770.306.7464.
Kasandas Properties
New Comfort Suites Hotel
 Suaboe Road, at Chastain Road, Marietta, Ga. 30144

CLIENT:
 PROJECT:

No.	Description	Rev.



Millwork Elevations and Sections

Project Number: 6003
 Date: 2/20/06
 Drawn by: VP
 Checked by: ID
A701
 Title:

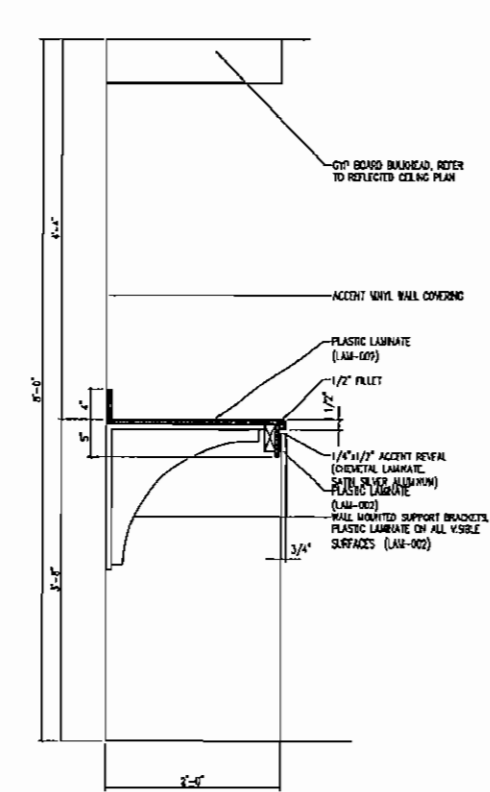

REF: A701
12 MILLWORK SECTION
 SCALE: 1" = 1'-0"

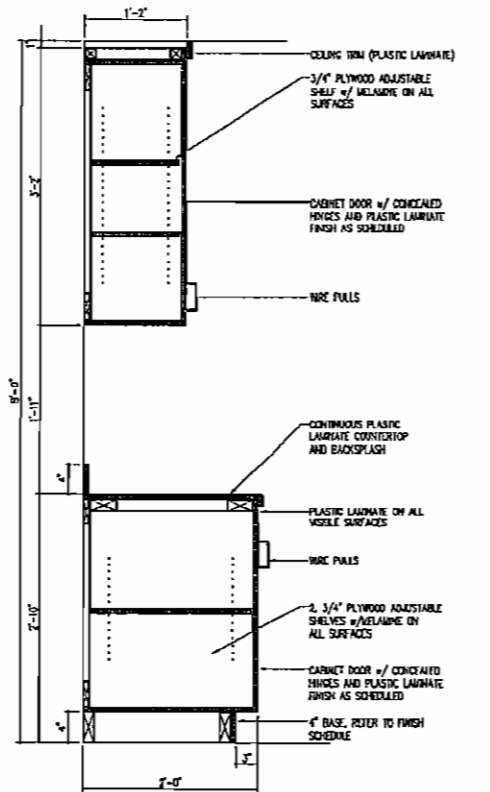

REF: A701
11 MILLWORK SECTION
 SCALE: 1" = 1'-0"

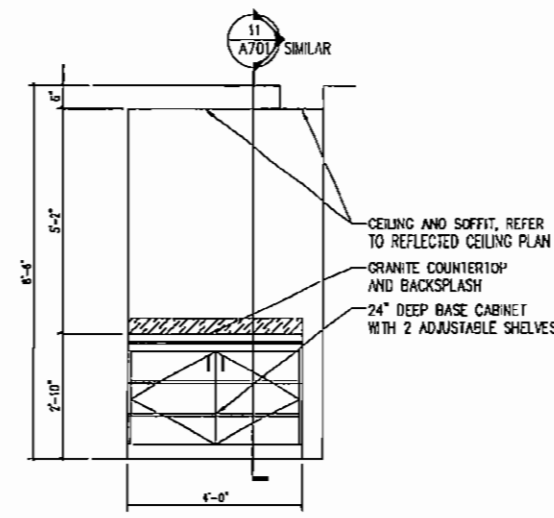

REF: A501
13 MILLWORK ELEVATION
 SCALE: 1/2" = 1'-0"

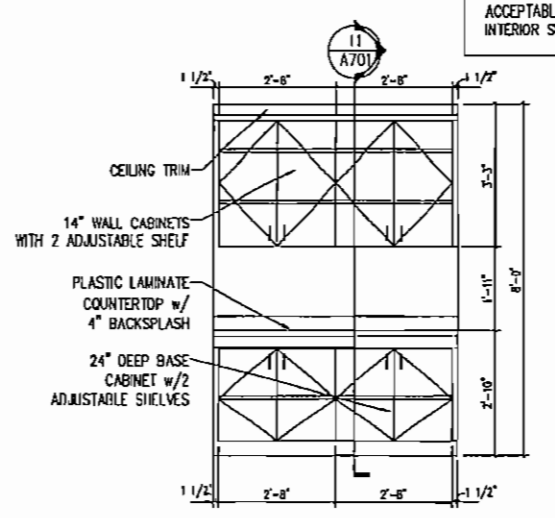

REF: A501
09 MILLWORK ELEVATION
 SCALE: 1/2" = 1'-0"

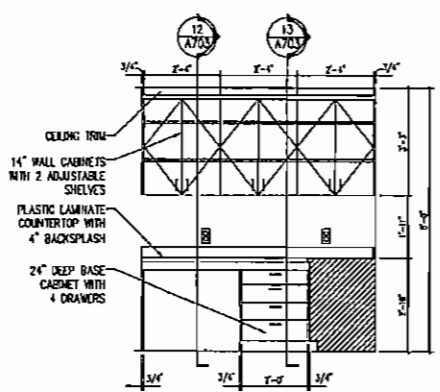

REF: A501
08 MILLWORK ELEVATION
 SCALE: 3/8" = 1'-0"

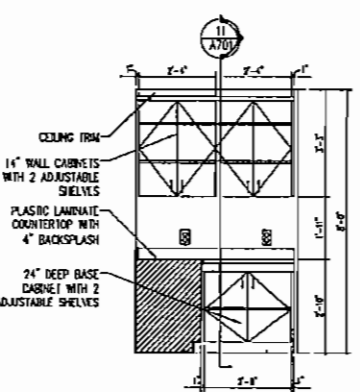

REF: A501
07 ELEVATION

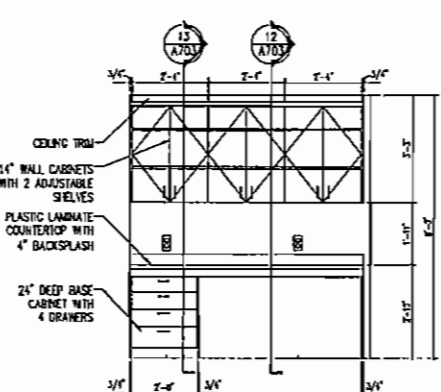

REF: A501
06 MILLWORK ELEVATION
 SCALE: 3/8" = 1'-0"

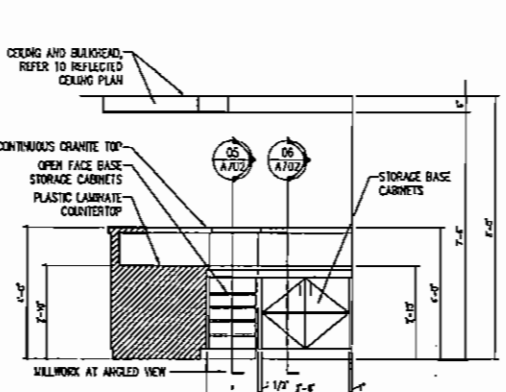

REF: 01 / A701
05 MILLWORK ELEVATION
 SCALE: 3/8" = 1'-0"

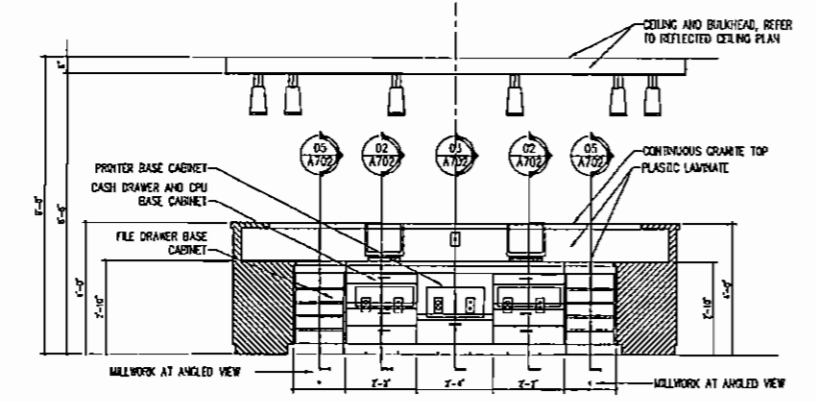

REF: 01 / A701
04 MILLWORK ELEVATION
 SCALE: 3/8" = 1'-0"

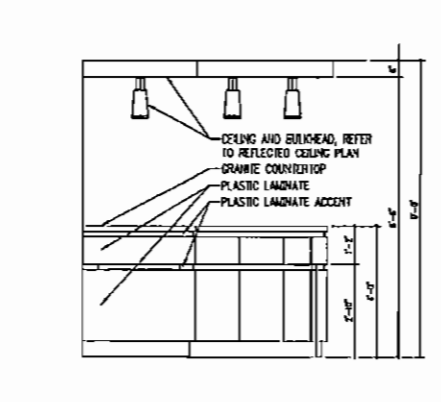

REF: 01 / A701
03 MILLWORK ELEVATION

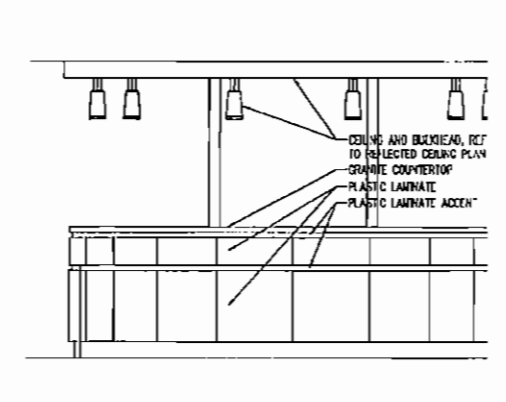

REF: 01 / A701
02 MILLWORK ELEVATION
 SCALE: 3/8" = 1'-0"

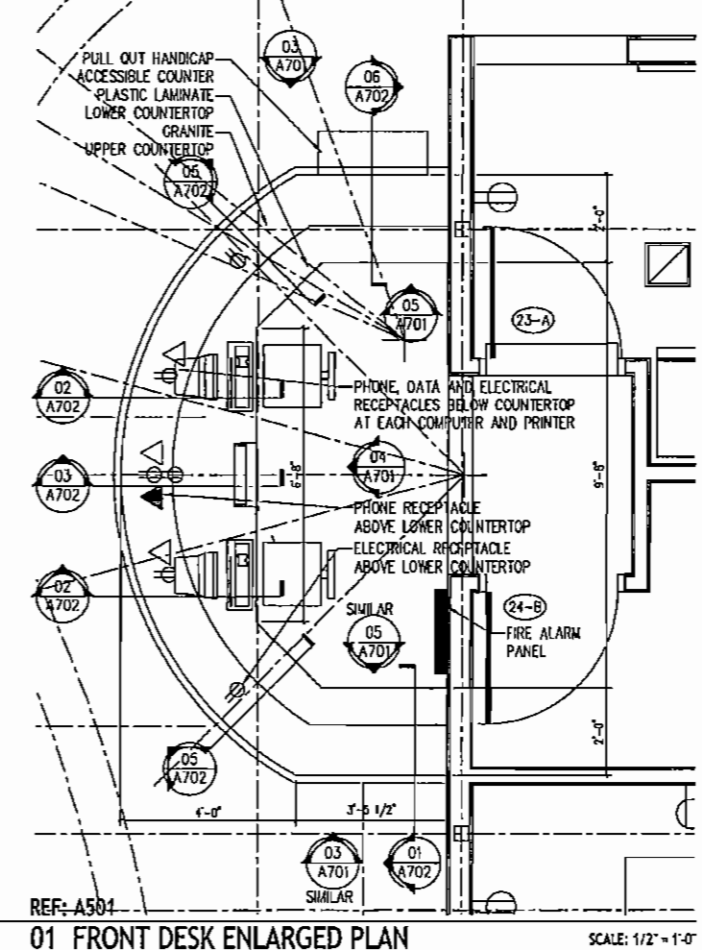

REF: A501
01 FRONT DESK ENLARGED PLAN
 SCALE: 1/2" = 1'-0"

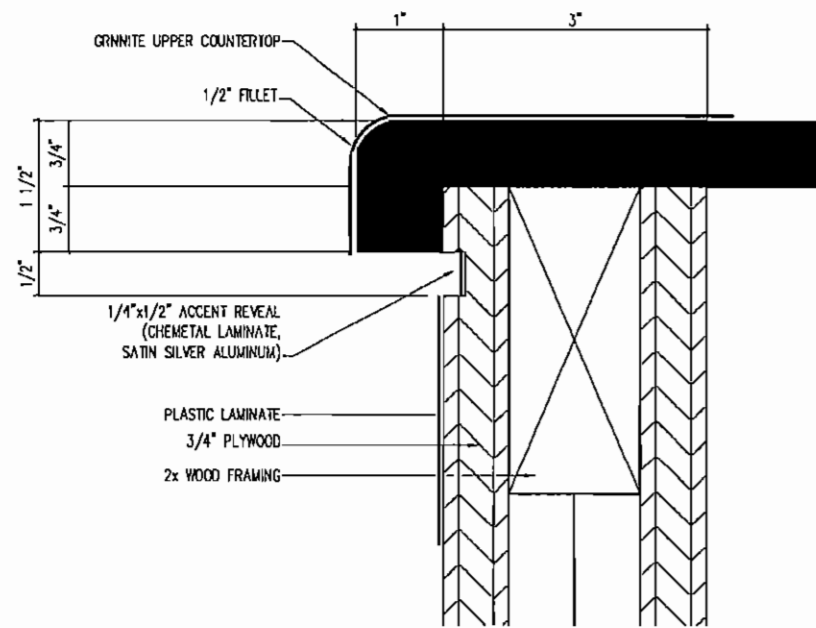

REF: 01 / A702
08 MILLWORK DETAIL

SCALE: FULL SIZE

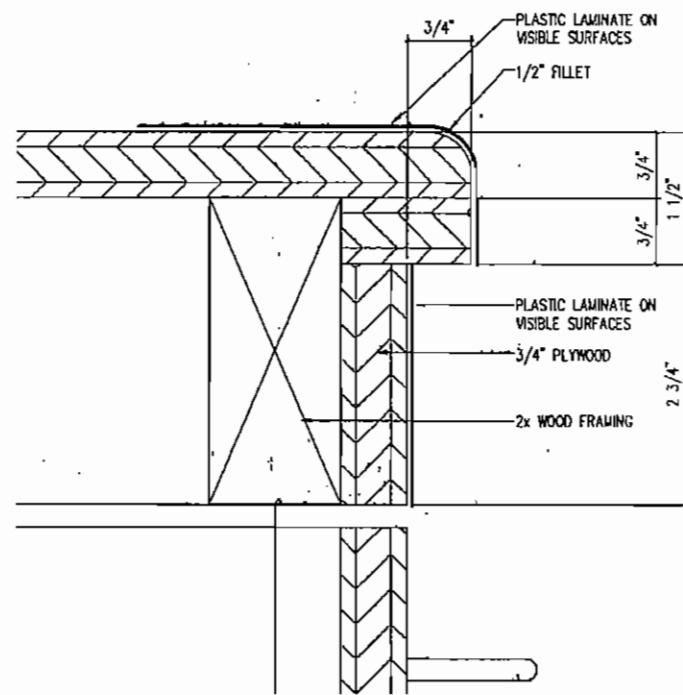

REF: 01 / A702
07 MILLWORK DETAIL

SCALE: FULL SIZE

REF: A501

09 STORAGE SHELVING SECTION

SCALE: 3/4" = 1'-0"

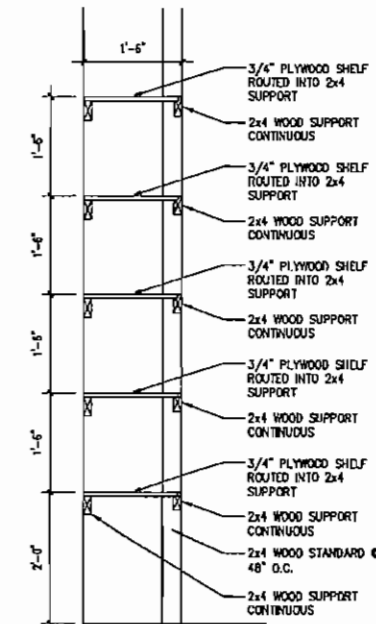

- NOTES:
1. ALL SURFACES TO BE PAINTED WITH SEMI-GLOSS PAINT. SAND PRIOR TO PAINTING.
 2. FIVE SHELVES AT GROUND FLOOR STORAGE ROOMS.
 3. FOUR SHELVES AT STORAGE ROOMS ON FLOORS 2 THRU 4.



ARCHITECTURAL DESIGN WORKSHOP P.C.

814 COVERED BRIDGE WAY, FARGO, GA. 30213. TEL. 770.306.7464.

Kasandas Properties

New Comfort Suites Hotel

Bubbas Road, at Claxton Road, Kennewick, Ga. 30144

CLIENT:

PROJECT:

No.	Description	Date



Millwork Elevations and Sections

- MILLWORK GENERAL NOTES:
1. MILLWORK ELEVATIONS AND SECTIONS ARE PROVIDED FOR INFORMATION ONLY, AND ARE NOT INTENDED FOR CONSTRUCTION.
 2. SUBMIT FINAL MILLWORK CONSTRUCTION DOCUMENTS FOR APPROVAL PRIOR TO FABRICATION.
 3. FINISHED MILLWORK AND INSTALLATION BY GENERAL CONTRACTOR, OWNER SHALL PROVIDE ALL EQUIPMENT.
 4. ALL SURFACES SHALL BE 3/4" PLYWOOD OR AS ALLOWED BY AM QUALITY STANDARDS #400 FOR "CUSTOM QUALITY MILLWORK."
 5. PLASTIC LAMINATE AS SCHEDULED ON ALL EXPOSED SURFACES. WHITE MELAMINE IS ACCEPTABLE ON ALL NON EXPOSED INTERIOR SURFACES.

Project Number	6003
Date	2/20/06
Drawn by	VP
Checked by	ID
	A702

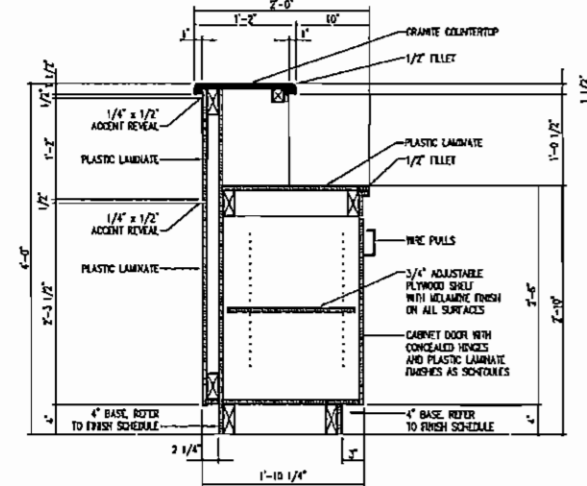

REF: 01 / A701
06 MILLWORK SECTION

SCALE: 1" = 1'-0"

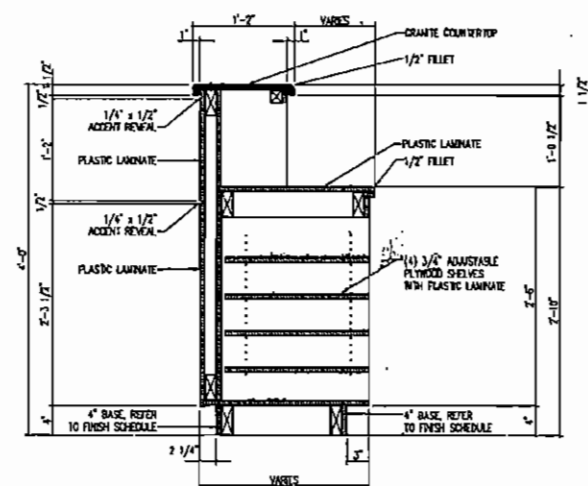

REF: 01 / A701
05 MILLWORK SECTION

SCALE: 1" = 1'-0"

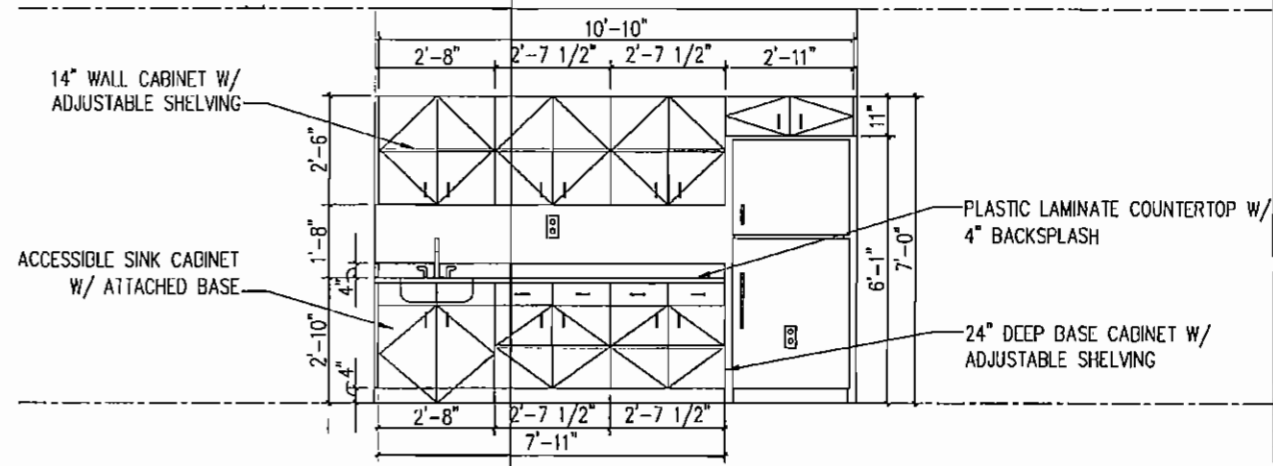

REF: 01 / A701
04 MILLWORK ELEVATION

SCALE: 1/2" = 1'-0"

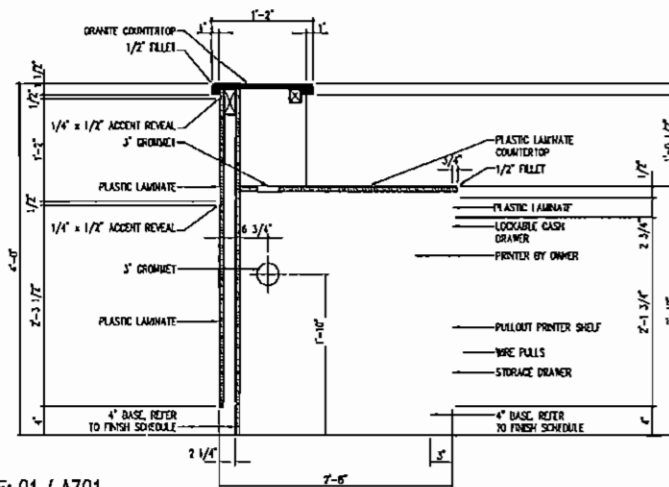

REF: 01 / A701
03 MILLWORK SECTION

SCALE: 1" = 1'-0"

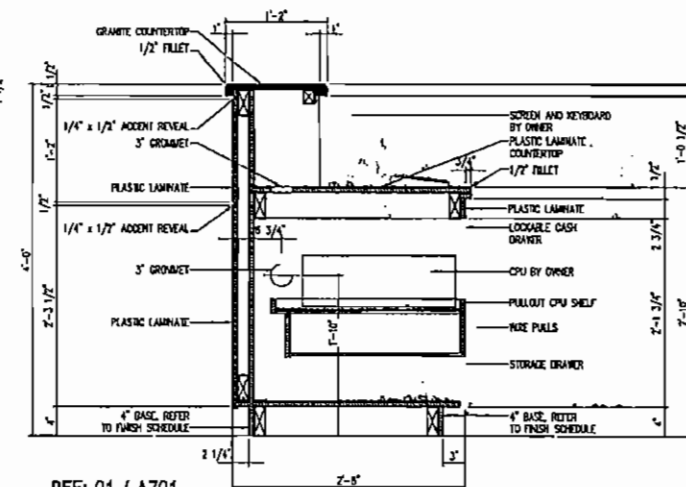

REF: 01 / A701
02 MILLWORK SECTION

SCALE: 1" = 1'-0"

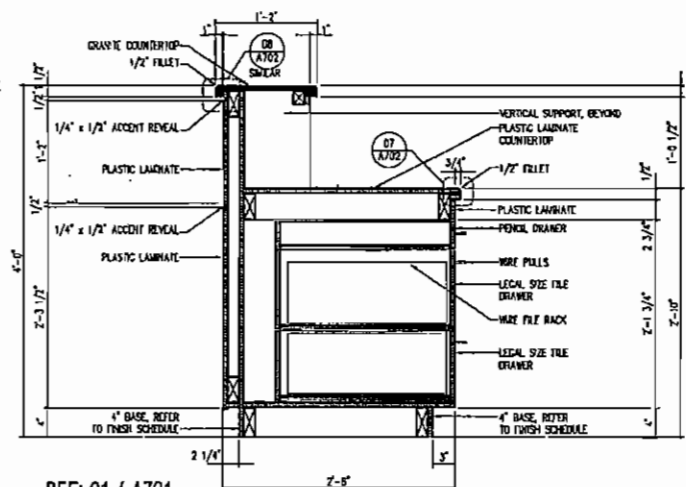

REF: 01 / A701
01 MILLWORK SECTION

SCALE: 1" = 1'-0"



ARCHITECTURAL DESIGN WORKSHOP P.C.
814 COVERED BRIDGE WAY, FARMING, GA. 30211, TEL. 770.306.7464.

Kasandas Properties

New Comfort Suites Hotel
Buckner Road, at Chastain Road, Kennesaw, GA. 30144

CLIENT:
PROJECT:

NO.	DESCRIPTION	DATE



Project Number	6003
Date	2/20/06
Drawn by	VP
Quantity	RD
Scale	A703

Millwork Elevations and Sections

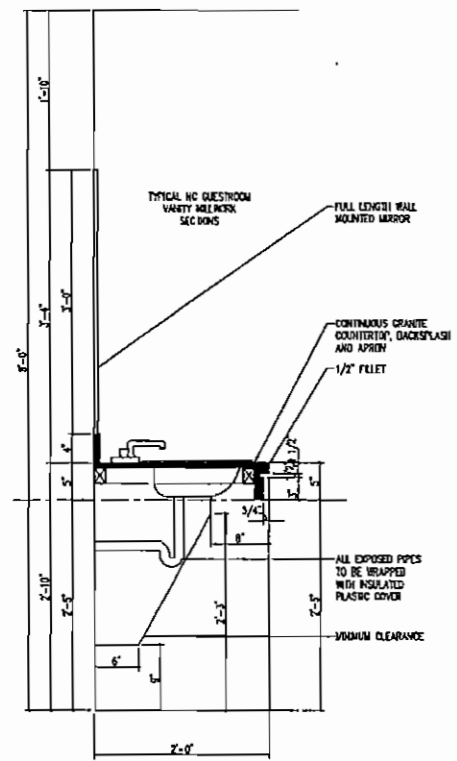

REF: 10/A507, 10/A509
15 MILLWORK SECTION SCALE: 1" = 1'-0"

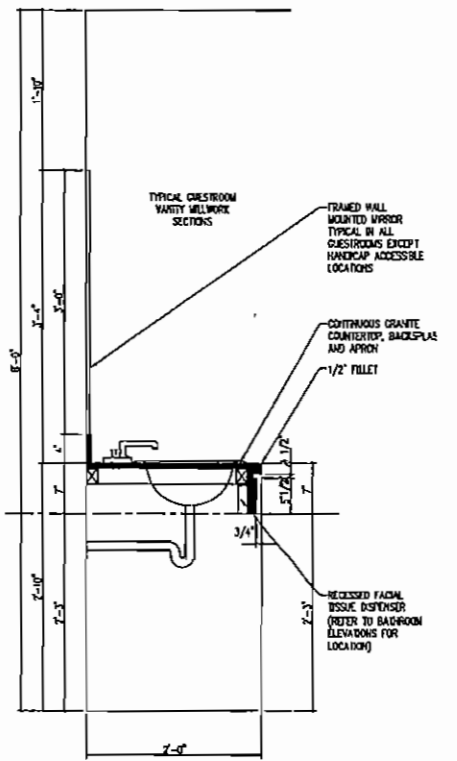

REF: 10/A505, 10/A506, 10/A508
14 MILLWORK SECTION SCALE: 1" = 1'-0"

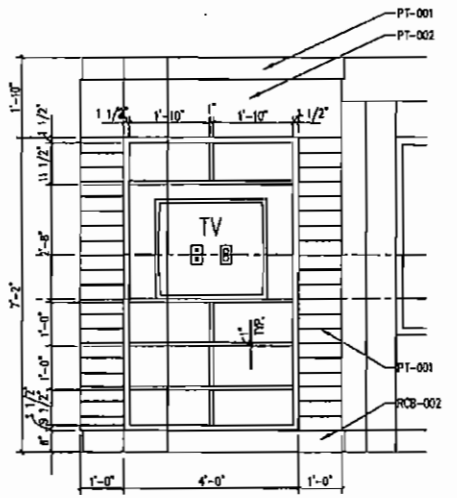

REF: 01 / A505
03 MILLWORK ELEVATION SCALE: 1/2" = 1'-0"

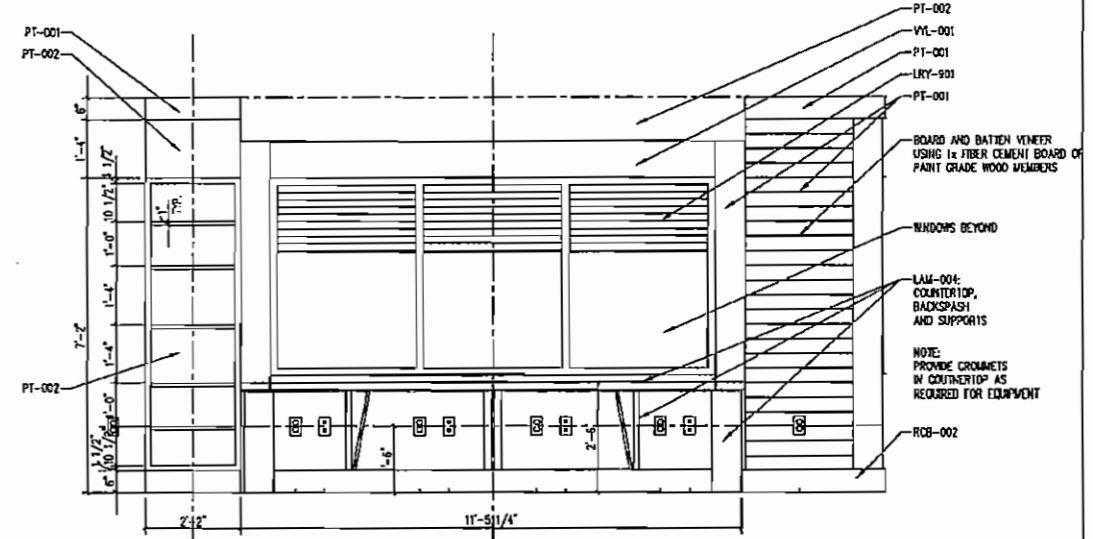

REF: 01 / A505
02 MILLWORK ELEVATION SCALE: 1/2" = 1'-0"

- MILLWORK GENERAL NOTES:**
- MILLWORK ELEVATIONS AND SECTIONS ARE PROVIDED FOR INFORMATION ONLY, AND ARE NOT INTENDED FOR CONSTRUCTION.
 - SUBMIT FINAL MILLWORK CONSTRUCTION DOCUMENTS FOR APPROVAL PRIOR TO FABRICATION.
 - FINISHED MILLWORK AND INSTALLATION BY GENERAL CONTRACTOR, OWNER SHALL PROVIDE ALL EQUIPMENT.
 - ALL SURFACES SHALL BE 3/4" PLYWOOD OR AS ALLOWED BY AWI QUALITY STANDARDS #400 FOR "CUSTOM QUALITY MILLWORK."
 - PLASTIC LAMINATE AS SCHEDULED ON ALL EXPOSED SURFACES. WHITE MELAMINE IS ACCEPTABLE ON ALL NON EXPOSED INTERIOR SURFACES.

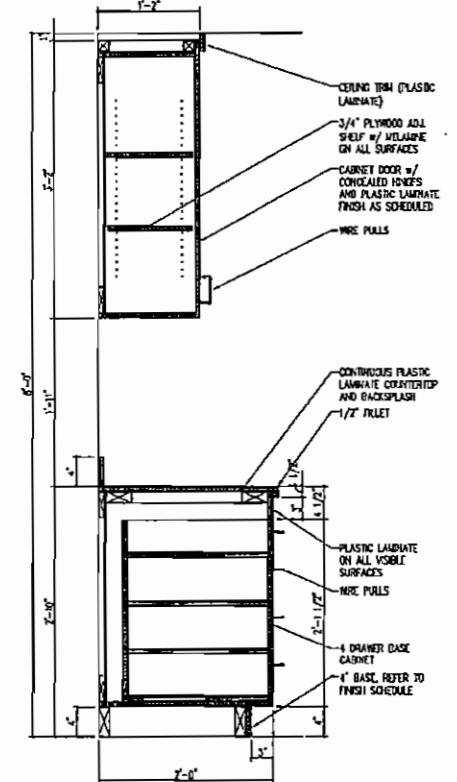

REF: 06/A701, 08/A701
13 MILLWORK SECTION SCALE: 1" = 1'-0"

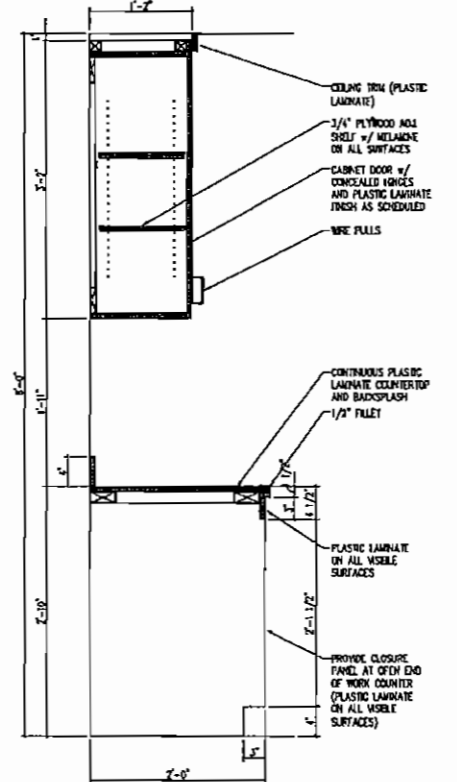

REF: 06/A701, 08/A701
12 MILLWORK SECTION SCALE: 1" = 1'-0"

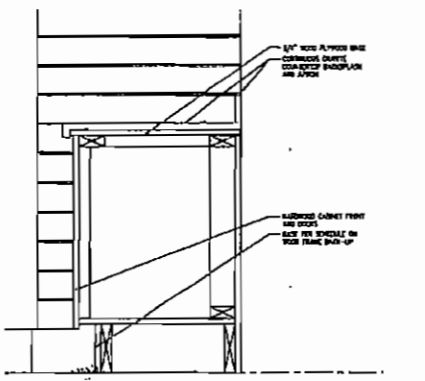

REF: 11 / A505
06 MILLWORK SECTION SCALE: 1" = 1'-0"

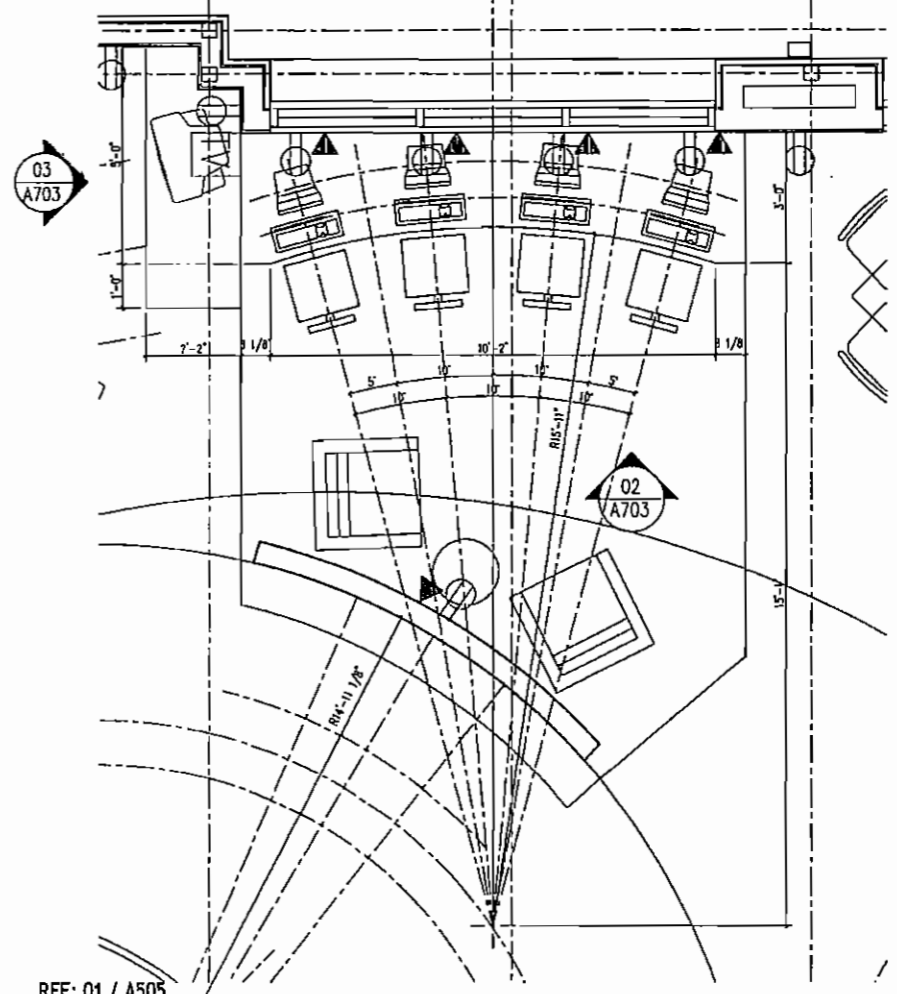

REF: 01 / A505
01 MILLWORK ELEVATION SCALE: 1/2" = 1'-0"